



# THIN FILM RESISTORS

TNPW – Tin/Lead Solder Contacts



## Thin Film, Rectangular, Precision Chip Resistors

### KEY BENEFITS

- Tolerances: down to  $\pm 0.1\%$
- Temperature coefficient: from  $\pm 10$  ppm/K to  $\pm 50$  ppm/K
- Tin/lead (Pb) solder contacts
- Very low electrical noise
- Broad range of industry standard sizes: 0402, 0603, 0805, 1206, 1210, 2010, and 2512

### APPLICATIONS

- Navigation and avionics instrumentation
- Medical and test equipment
- Automotive instrumentation
- Telecommunication

Datasheet is available on our web site at [www.vishay.com](http://www.vishay.com)  
for TNPW - <http://www.vishay.com/doc?31006>

# High-Stability Thin Film Flat Chip Resistor

≤ 0.05 % (1000 h rated power at 70 °C)



## FEATURES

- Metal film layer on high quality ceramic
- Protective top coat
- Tin/lead (Pb) solder contacts
- Excellent overall stability at different environmental conditions ≤ 0.05 % (1000 h rated power at +70 °C)
- Low temperature coefficient and tight tolerances (± 0.1 %; ± 10 ppm/K)

## APPLICATIONS

- Automotive
- Telecommunication
- Medical Equipment
- Industrial Equipment

TNPW Precision Thin Film Flat Chip Resistors are the perfect choice for most fields of modern electronics where reliability and stability is of major concern. Typical applications include telecommunication, industrial, medical equipment, high-end computer and audio/video electronics.

STANDARD ELECTRICAL SPECIFICATIONS			
	TNPW0402	TNPW0603	TNPW0805
Metric Size	RR 1005M	RR 1608M	RR 2012M
Resistance range	10 Ω to 100 kΩ	10 Ω to 332 kΩ	10 Ω to 1 MΩ
Resistance tolerance	± 1 %; ± 0.5 %; ± 0.1 %		
Temperature Coefficient	± 50 ppm/K; ± 25 ppm/K; ± 15 ppm/K; ± 10 ppm/K		
Climatic category (LC7/UCT7/days)	55/125/56	55/125/56	55/125/56
Rated dissipation, P <sub>70.2</sub> <sup>3)</sup>	0.063 W	0.1 W	0.125 W
Operating voltage, U <sub>max</sub> , AC/DC	50 V	75 V	150 V
Maximum permissible film temperature	155 °C	155 °C	155 °C
Thermal resistance <sup>3)</sup>	870 K/W	550 K/W	440 K/W
Insulation voltage:			
U <sub>ins</sub> , 1 min	75 V	100 V	200 V
continuous	75 V	75 V	75 V
Failure rate	≤ 0.3 x 10 <sup>-9</sup> /h	≤ 0.3 x 10 <sup>-9</sup> /h	≤ 0.3 x 10 <sup>-9</sup> /h
Weight/1000 pcs.	0.65 g	2 g	5.5 g

<sup>1)</sup> Size not specified in EN 140401-801

<sup>2)</sup> Rated voltage,  $\sqrt{P \cdot R}$ . The power dissipation on the resistor generates a temperature rise against the local ambient, depending on the heat flow support or the printed-circuit board (thermal resistance). The rated dissipation applies only if the permitted film temperature is not exceeded

<sup>3)</sup> Measuring conditions in accordance with EN 140401-801

- TNPW 0402 without marking
- Extended values, tighter tolerances and temperature coefficient available on request

## DIMENSIONS

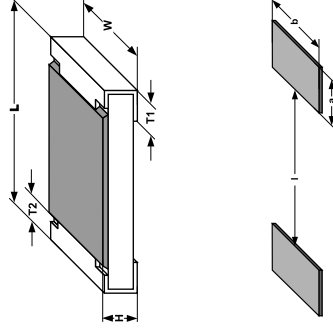

SIZE		DIMENSIONS millimeters					
INCH	METRIC	L	W	H	T1	T2	
0402	1005	1.0 ± 0.05	0.5 ± 0.05	0.35 ± 0.05	0.2 ± 0.10	0.2 ± 0.10	
0603	1608	1.6 ± 0.10	0.85 ± 0.10	0.45 ± 0.10	0.3 ± 0.20	0.3 ± 0.20	
0805	2012	2.0 ± 0.15	1.25 ± 0.15	0.45 ± 0.10	0.4 ± 0.20	0.4 ± 0.20	
1206	3216	3.2 ± 0.15	1.6 ± 0.15	0.55 ± 0.10	0.5 ± 0.25	0.5 ± 0.25	
1210	3225	3.2 ± 0.15	2.45 ± 0.15	0.60 ± 0.15	0.5 ± 0.25	0.5 ± 0.25	
2010	5025	5.0 ± 0.15	2.5 ± 0.15	0.60 ± 0.15	0.6 ± 0.25	0.6 ± 0.25	
2512	6332	6.3 ± 0.20	3.1 ± 0.15	0.60 ± 0.15	0.6 ± 0.25	0.6 ± 0.25	

SIZE		SOLDER PAD DIMENSIONS millimeters					
INCH	METRIC	a	b	i	a	b	i
0402	1005	0.4	0.6	0.5	-	-	-
0603	1608	0.5	0.9	1.0	0.9	0.9	1.0
0805	2012	0.7	1.3	1.2	0.9	1.3	1.3
1206	3216	0.9	1.7	2.0	1.1	1.7	2.3
1210	3225	0.9	2.5	2.0	1.1	2.5	2.3
2010	5025	1.0	2.5	3.9	1.2	2.5	3.9
2512	6332	1.0	3.2	5.2	1.2	3.2	5.2

## PART NUMBER AND PRODUCT DESCRIPTION

Products can be ordered using either the Product Description or the Part Number. For ordering TNPW with lead (Pb)-free contacts please refer to latest edition of data sheet TNPW e3.

Part Number: (TIN LEAD) TNPW12061K32BETA

T	N	P	W	1	2	0	6	1	K	3	2	D	E	T	A		
MODEL	TNPW0402	TNPW0603	TNPW0805	TNPW1206	TNPW1210	TNPW2010	TNPW2512									PACKING <sup>1)</sup>	SPECIAL
VALUE	R = Decimal K = Thousand (4 digits)															TA	up to 2 digits
TOLEANCE	B = ± 0.1 % K = ± 0.5 % F = ± 1.0 %															TC	Blank = standard
TCR	H = ± 50 ppm/K K = ± 25 ppm/K X = ± 45 ppm/K Y = ± 10 ppm/K															TD	
RESISTANCE VALUE Ω	Examples: 1K32 = 1320 Ω 99.68K = 99 680 Ω 360 = 360 Ω															TF	
TOLERANCE	± 0.1 % ± 0.5 % ± 1.0 %															TG	
1.32K															TN		
RESISTANCE VALUE Ω	Examples: 1K32 = 1320 Ω 99.68K = 99 680 Ω 360 = 360 Ω															TV	
0.5 %															RT1		
TCR	T-2 = ± 50 ppm/K T-6 = ± 25 ppm/K T-10 = ± 15 ppm/K T-13 = ± 10 ppm/K															PACKING <sup>1)</sup>	
RT1															RT1		
PACKING <sup>1)</sup>															RT6		
															RT7		
															RT2		
															RT5		

<sup>1)</sup> Please refer to PACKING table

NOTICE: Specifications of the products displayed herein are subject to change without notice. Vishay Intertechnology, Inc. or anyone on its behalf, assumes no responsibility or liability for any errors or inaccuracies. Information contained herein is intended to provide a product description only. No license, express or implied, by estoppel or otherwise, to any intellectual property rights is granted by this document. Except as provided in Vishay's terms and conditions of sale for such products, Vishay assumes no liability whatsoever and disclaims any express or implied warranty, relating to sale and/or use of Vishay products including liability or warranties relating to fitness for a particular purpose, merchantability or infringement of any patent, copyright, or other intellectual property right. The products shown herein are not designed for use in medical, life-saving, or life-sustaining applications. Customers using or selling these products for use in such applications do so at their own risk and agree to fully indemnify Vishay for any damages resulting from such improper use or sale.